



Multi-level protection for your peace of mind

The Xport[®] Drain System features a multi-level design and a unique cover that provides an added layer of protection to decrease the likelihood of a swimmer's body creating a vacuum and forming a seal against the drain. Plus, the drain's large open space, a smooth sweeping design, and 2.5-inch plumbing help reduce hair entanglement.

- Design features an anti-entrapment second drain so in the event the main drain is covered, the suction immediately releases by diverting to the second, uncovered drain.
- Cover design features a large, uneven surface that greatly decreases the likelihood of a seal being formed between swimmer and drain.
- Compliant with ASME/ANSI A112.19.8M.
- IAPMO listed.



Xport meets all requirements of the Uniform Swimming Pool, Spa and Hot Tub Code™

Xport[®] Drain System By Pentair Water Pool and Spa[™]

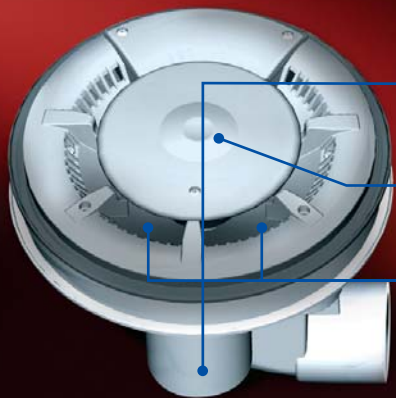

Large 2 1/2" fitting promotes efficient flow for effective debris removal

Cover has large, uneven surface to reduce chances of a seal forming between swimmer and drain

Large openings between cover and rest of drain assembly help reduce hair entanglement



Fast and powerful cleaning, too

Xport[®] also efficiently whisks debris away from the bottom of your pool, spa, overflow basin, or fountain.

- Unique funnel shape compresses and directs debris to the outlet port for faster, more powerful removal of foreign materials with less likelihood of blockage.
- Optional debris canister mounts in your deck just like a skimmer and is just as easy to empty. Holds more debris than most pump baskets for less frequent servicing.
- Available for gunite, vinyl liner and fiberglass pools in a choice of colors to match surfaces and disappear from view.



Xport is available in white, light blue, black and gray for gunite pools; white and light blue for vinyl and fiberglass pools

Available from:



Pentair Water
Pool and Spa[™]

Pentair Pool Products[®]
800.831.7133
www.pentairpool.com

Sta-Rite[®]
800.831.7133
www.staritepool.com

pumps / filters / heaters / heat pumps / automation / lighting / cleaners / sanitizers / maintenance products